



A Donaldson Company

A WORLD LEADER IN FUME
EXTRACTION TECHNOLOGY

DustPRO 400

USER MANUAL



Contents

1	01	Overview of your DP400 system (front)
	02	Overview of your DP400 system (back)
2	01	Important safety notes
	02	Safety labels
3	01	Unpacking and unit placement
4	01	Fume capture methods
	02	Connecting to power supply
	03	Optional added features
	04	Optional added features (cont'd)
5	01	Turning extractor On / Setting the airflow
6	01	Cleaning the unit / Pre-filter replacement
	02	HEPA filter replacement
7	01	Fault indication / Error codes
8	01	Consumables spares / Filter disposal
9	01	DP 400 Specifications

Overview



1 01

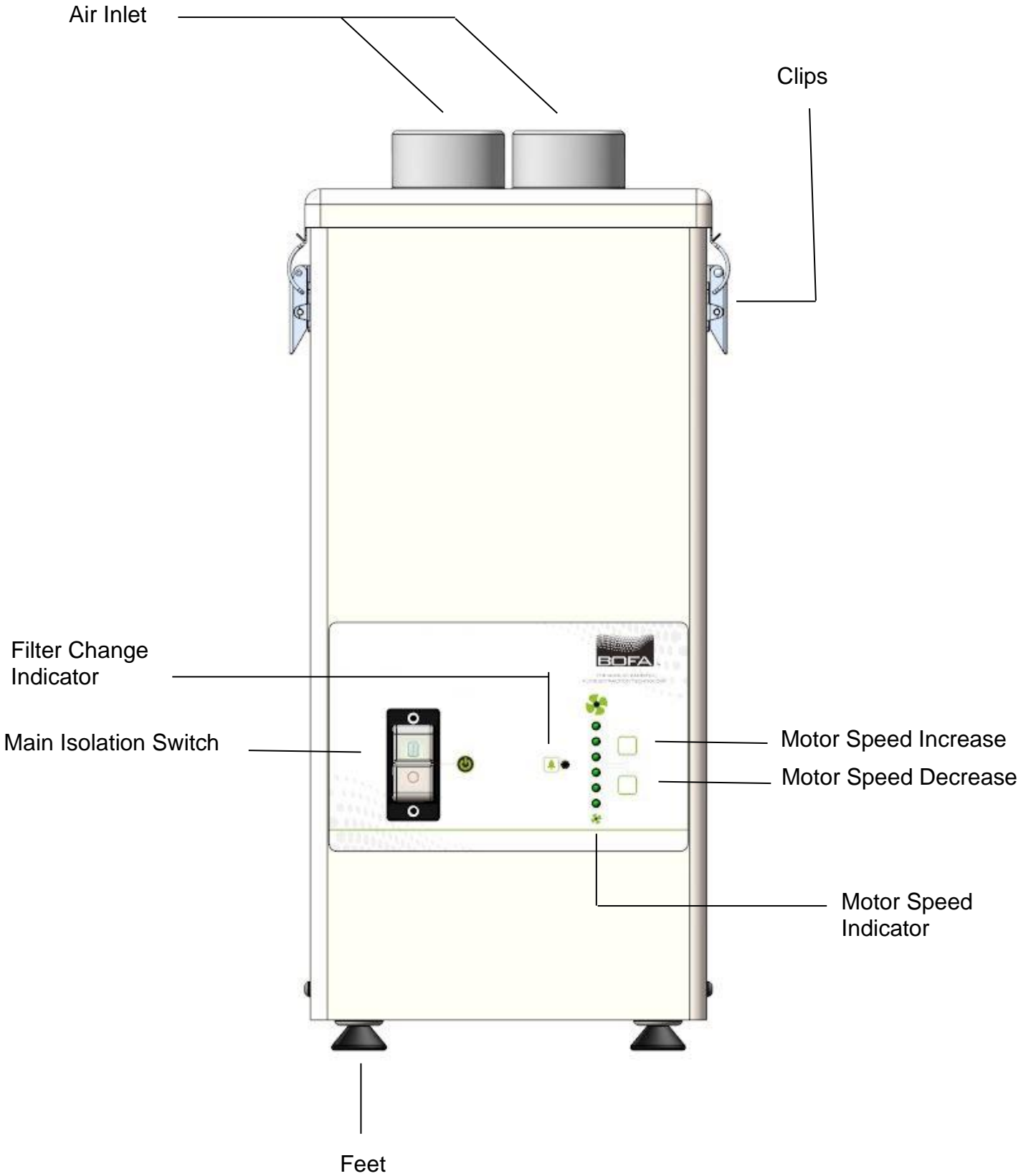

Overview



1 02

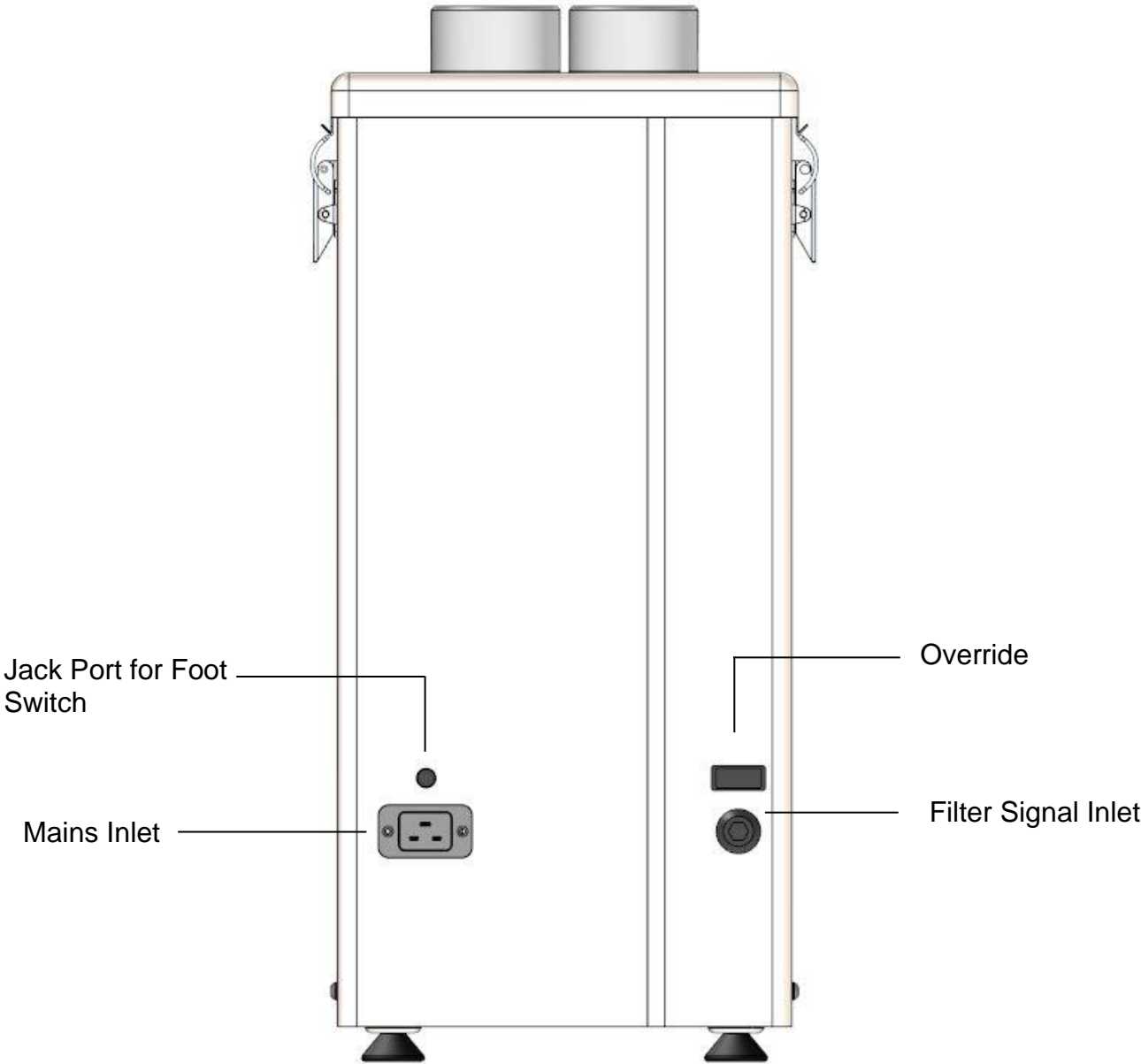

Safety Instructions



Important safety notes

Concerning symbols used on the extraction unit and referred to within this manual.



Danger

Refers to an immediately impending danger. If the danger is not avoided, it could result in death or severe (crippling) injury. Please consult the manual when this symbol is displayed.



Warning

Refers to a possibly dangerous situation. If not avoided it could result in death or severe injury. Please consult the manual when this symbol is displayed.



Caution

Refers to a possibly harmful situation. If not avoided, damage could be caused to the product or something in its environment.



Important (Refer to manual)

Refers to handling tip and other particularly useful information. This does not signify a dangerous or harmful situation. Refer to manual when this symbol is displayed.

Electrical Safety

The DP400 system has been designed to meet the safety requirements of the Low Voltage Directive 2006/95/EC (previously numbered 73/23/EEC)

Warning

When working with the pump/motor housing open, Live 230/115 volt mains components are accessible. Ensure that the rules and regulations for work on live components are always observed.

Important

To reduce the risk of fire, electric shock or injury:

1. Always isolate the system from the mains power supply before removing the pump/motor access panel.
2. Use only as described in this manual.
3. Connect the system to a properly grounded outlet.

Dangers to eyes, breathing and skin

Once used, the filters within the DP400 system may contain a mixture of particulates, some of which may be sub-micron size. When the used filters are moved it may agitate some of this particulate, which could get into the breathing zone and eyes of the operative. Additionally, depending on the materials being processed, the particulate may be an irritant to the skin.

Caution: When changing used filters always wear a mask, safety shoes, goggles and gloves.

BOFA Technical Service

If a problem arises with your DP400. Please refer to the troubleshooting guide section 7 of this manual. If the problem is still not resolved, please:

- Visit our website at www.bofa.co.uk for on-line help.
- Or contact the helpline on **+44 (0) 1202 699 444**, Mon-Fri, 9am-5pm.
Email: Technical@bofa.co.uk

Serial Number

For future reference, fill in your DP400 details in the space provided. The serial number is on the rating label located on the rear of the unit.

Serial Number:

□□/□□-DP400-□□□□

Safety Instructions



Warning and Information labels

The following listing details labels used on your DP400 unit.

Goggles, Gloves & Mask Label



Location: On the filter tray

Meaning: Goggles, Gloves and Masks should be worn while handling used filters.

Electrical Danger



Location: Lower Side next to base screws

Meaning: Removal of panels with this label attached will allow access to potentially live components.

Warning Label



Location: Upper Side next to latches.

Meaning: Power should be isolated before the panel with this label attached is opened/ removed.

Serial Number Label



Location: Lower Rear of unit next to mains inlet.

Meaning: This label contains a variety of information about the extraction unit, including.

- Company name
- Extractor model
- Unit serial number
- Operating voltage range
- Maximum current load
- Operating frequency
- Relevant approval markings/ logos

PLEASE NOTE: If the equipment is used in a manner not specified by the manufacturer, the protection provided by the equipment maybe compromised.

Fire Risk Warning

In the very rare event that a burning ember or spark is drawn into the fume extraction unit, it may be possible that the filters will ignite.

Whilst any resultant fire would typically be retained within the fume extraction unit, the damage to the extractor would be significant.

It is therefore essential to minimise this risk by undertaking an appropriate assessment to determine:-

- a). Whether additional fire protection equipment should be installed.
- b). Appropriate maintenance procedures to prevent the risk of build-up of debris which could potentially combust.

This unit should not be used on processes with sparks of flammable materials or with explosive dusts and gases, without implementation of additional precautions.

It is essential that nozzles or other extraction/fume capture devices and hoses/pipework are cleaned regularly to prevent the build-up of potentially ignitable debris.

Before installation

3 01

Packaging removal & unit placement

Before installation, check the extraction unit for damage. All packaging must be removed before the unit is connected to the power supply.

Please read all instructions in this manual before using this extractor.

1. Move the unit to the location where it is going to be installed and remove the outer packaging. **This unit should be installed in a well-ventilated area.**



Caution

Due to the weight of the extractor suitable lifting equipment should be used and with regard to appropriate safety precautions. (See Appendix for product weight details)



Caution

Do not block or cover the cooling vents on the unit, as this severely restricts airflow and may cause damage to the unit.



Caution

Under no circumstances should the exhaust outlet/s be covered as this will restrict the airflow and cause overheating.

2. Check the filters are located in their correct position before closing the door and securing the door latches.

Installation

4 01

During the machining processes which remove material, dust is usually generated as a by-product. This dust needs to be removed in order to prevent interference with the performance of the machine and also to protect the health of the operator. The Dust Pro range of units has been developed to provide effective removal of swarf and smaller particulates created during processes such as routing, mechanical engraving, grinding and lathing. Dust Pro units are compact and portable. They are of robust design, and feature ease of use with minimal maintenance and long life.

Exposure to airborne contaminants at work, such as inhalable and respirable dust particles, can put people's health at risk. Health and safety regulations require employers to control exposure to hazardous substances in order to prevent ill health. The use of a suitable extraction system will enable you to conform to the Health and Safety regulations and protect the health employees and others.

The DP400 has been designed to remove and filter fume containing potentially hazardous particulate generated during manufacturing processes. Such hazardous substances are captured within a multistage filtration system after which the cleaned air is returned to the workplace.

Fume Capture Methods

The fume is normally captured by 1 of 3 methods.

- Flexible arm/ Nozzle
- Enclosures
- Cabinets

General Guidelines for a successful installation

- Keep duct run length to a minimum
- Avoid sharp bends / turns in the ductwork
- Avoid multiple bends / turns in the ductwork
- Use a larger diameter duct where able
- Position the capture device as close as possible to the marking point. (if used on high speed lines, position the capture device slightly downstream)

Flexible Arm & Nozzle Extraction (Optional Kits)

The stay put arm should be mounted as close as possible to the marking point using the horseshoe clips. Unscrew the push fit connector from the other side of the flexible hose.

Cut the flexible hose to suit the distance back to the extractor connection and push onto the extractor inlet. Purge air should be kept to a minimum, where possible, to prevent the fume being blown away from the nozzle.

Moving products

For applications where the product to be marked is moving past the stationary head the capture nozzle should be positioned as close as possible to the marking area on the side the product is moving towards.

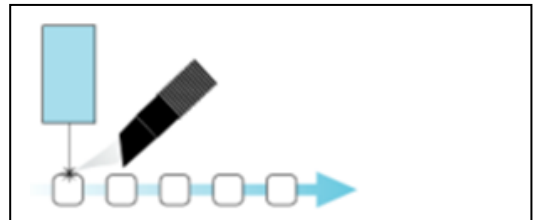

Enclosures

The extraction hose and nozzle can be attached to the enclosure surrounding the marking zone provided that the extraction point is within 50-75mm of the marking point.

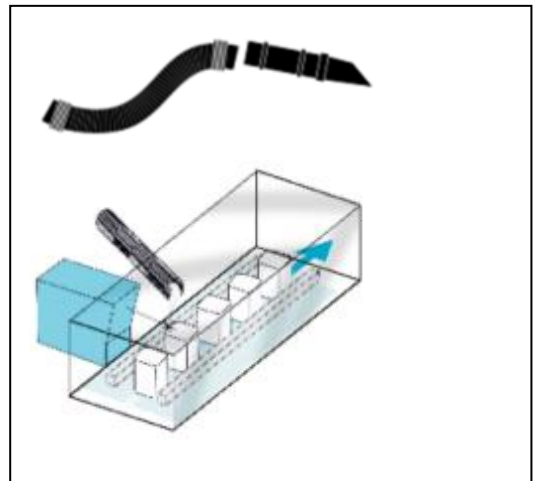

Cabinets

Cabinets normally have a 75mm or 100mm spigot for fume extraction. For best performance use the same diameter hose as the spigot and reduce at the extractor end if necessary. **Keep the hose run as short as possible.**

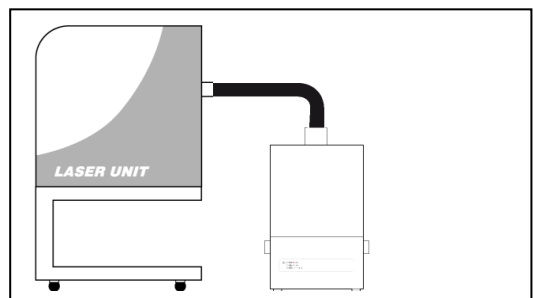

Installation



Specification

Dimensions: Height 595mm Depth 263mm Width 283mm

Weight: 9.1Kg

Voltage: 115-230V

Frequency: 50/60Hz

Full load current: 12.5A

Power: 1100w

Capacity: 400m³/h

Connection to Power Supply

Please follow the above specification when selecting the power supply outlet for the DP400, ensure the power supply is suitable before connecting the DP400.

Check the Integrity of the electrical power cable, if the supply cord is damaged the extraction unit should not be connected to the mains. The supply cord should only be replaced by a BOFA engineer as an electrical safety test may be required after replacement.

The DP400 unit **MUST** be connected to a properly earthed outlet.

If your DP400 was ordered with any optional extras please read section 4.03 before the power connection is made as additional connections may be required before power is connected to the extractor.

Connect the power cable to an isolated electrical supply.

The mains socket should be installed near the extractor it should be easily accessible and able to be switched On/ Off. The cable run should be arranged so as not to create a trip hazard.

Installation

4 03

Optional added features

The DP400 can be configured to suit customer specification. These optional extras would be discussed, arranged and installed prior to delivery.

(If unsure what features your DP400 is equipped with please contact the seller with the unit serial number, (Refer to section 2 for location) who will be able to advise what specification has been supplied.

Remote Stop/Start feature

Enables the extraction unit to be remotely turned On / Off via an external signal.

This feature can be configured in 3 ways

- DC Voltage input – Range 12-24VDC
- Override – Stop / Start feature switched off

Note: Care must be taken to ensure that the system is correctly wired in order for the extraction unit to function correctly.

DC Voltage input

This configuration requires the Black & Red cores of the signal cable (Refer to section 1 for location) to be connected to a known and tested DC power supply, in order to start the extractor.

The operating voltage for this signal is between 12 & 24VDC. Only voltages within this range should be connected. Voltages connected outside of this range may cause irreversible damage to the internal control PCB.

Red cable = V+

Black cable = V-

When the extractor is provided with the correct DC voltage the motor will start and maintain the set flow rate (Refer to section 5 for how to set the flow) when the DC voltage is removed the motor will slow down and come to a stop.

The extractor will need to be turned on (See section 5 for turning the extractor on) in order for this feature to operate.

Override

Enables the extractor to operate fully with or without either DC voltage input or the Volt free input.

The override feature can be toggled On / Off by a switch mounted on the internal motor access panel (see below for switch location)

Switch in "On" position

In this position the extractor will require a start signal (either Voltage input or Volt free, depending on the requested specification) to enable the motor within the extraction unit.

Switch in "Off" position

In this position the extractor motor will run without the requirement for an external start signal. This feature is useful for engineers carrying out works/ tests on the extractor without the need for the auxiliary signal being present.

Installation

4 04

Filter Blocked / System Fail Signal

With this option the DP400 will output a signal to alert the user when the extractor has blocked filters.

This feature will not directly stop the extractor from running correctly, but if fitted this feature should be terminated correctly before power is applied to the DP400.

Connection specification

This signal is available via the Green and White cores of the signal cable. The DP400 will provide a volt free Open / Closed signal that can be connected to an external interface, beacon or warning device. This should only be used on a volt-free circuit.

Filter Signal

When the filters become blocked the connection between the Green & White cables will become "Closed"

When the extraction system is running normally the connection between the Green & White cables will become "Open"

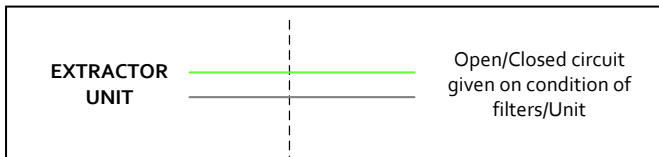

Operation

5₀₁

Turning extraction unit On

The DP400 is turned on and off by the main isolation switch on the rear of the unit. To turn "On" the (I) side of the green switch should be depressed (Refer to section 1 for switch location)

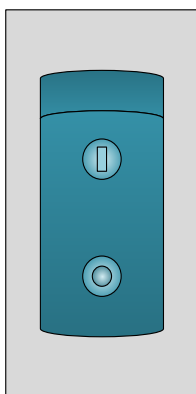

Motor Speed Adjustment

The motor speed can be adjusted by the buttons on the front of the extraction unit.

Pressing the Up arrow will increase the motor speed



Pressing the Down arrow will decrease the motor speed.

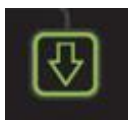

The 6 blue LED's on the front of the unit will display the motor speed, there are several increments between each LED so the button may need to be pressed several times to illuminate the next LED.

Maintenance

6 01

Maintenance UK

It is a legal requirement, under regulation 9 of the COSHH regulations that all local exhaust ventilation systems are thoroughly examined and tested at least once every 14 months (typically carried out annually). The approved code of practice recommends that a visual check should be carried out at least once a week.

COSHH requires the annual inspection and testing to be carried out by a competent person and specifies that documentation results are recorded in a log.

Contact the seller for more information about inspection and certification.

Maintenance General

User maintenance is limited to cleaning the unit and filter replacement, only the manufacturers trained maintenance technicians are authorised to carry out component testing and replacement. Unauthorised work or the use of unauthorised replacement filters may result in a potentially dangerous situation and/or damage to the extractor unit and will invalidate the manufacturer's warranty.

Cleaning the unit

The powder coat finished units can be cleaned with a damp cloth and non-aggressive detergent, do not use an abrasive cleaning product as this will damage the finish.

The cooling inlets and outlets should be cleaned once a year to prevent build-up of dust and overheating of the unit.

Replacing Filters

The filters will need changing when the Green LED on the front of the unit starts to flash Red.

At this point the Pre filter bag should be changed, if the Green LED has not returned then the HEPA filter should also be changed.

A log of the changes should be maintained by the user. The filters require attention when the LED flashes RED or when the extractor no longer removes fume efficiently.

It is recommended that a spare set of filters are kept on site to avoid prolonged unit unavailability. Part numbers for replacement filters can be found on the filters fitted in your system.

To prevent overheating, units should not be run with a blocked filter condition, or with dust obstruction of Inlets / Outlets.

Pre Filter Replacement

To replace the Pre filter follow the procedure detailed below.

Always use Goggles Gloves and Masks when changing the filters.

1. Isolate the electrical supply to the extractor
2. Undo the 2 latches on the side of the extractor
3. Lift the filter plate, this will allow access to the filter, slide the filter off the plate
4. Once removed it is recommended that the filters are bagged and sealed
5. Slide the new filter into place on the plate
6. Replace the lid and secure the 2 latches
7. Reconnect the mains supply to the unit.

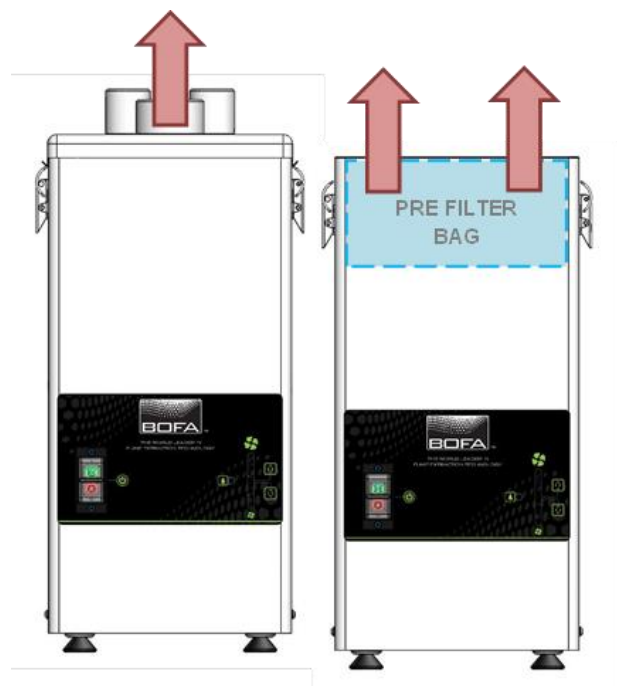

Maintenance

6 02

HEPA Filter Replacement

To replace the HEPA filter please follow the procedure below.

1. Isolate the electrical supply to the extractor
2. Undo the 2 latches on the side of the extractor
3. Lift the filter plate, this will allow the pre filter to be removed
4. Unscrew the 2 knobs holding the HEPA filter cage in place.
5. Remove the Cage and HEPA filter.
6. Once removed it is recommended that the filters are bagged and sealed
7. Fit the new filter and replace cage, secure in place.
8. Refit the Pre filter
9. Replace the lid and secure the 2 latches
10. Reconnect the mains supply to the unit.

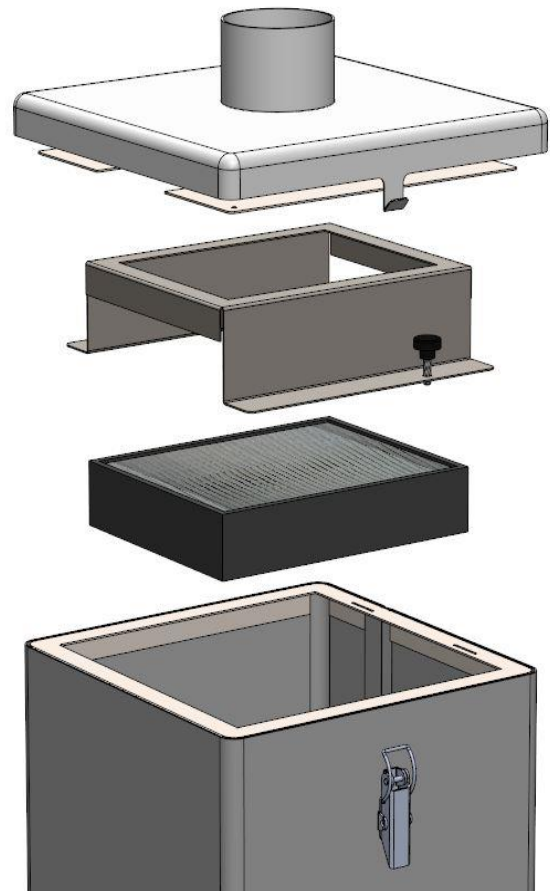
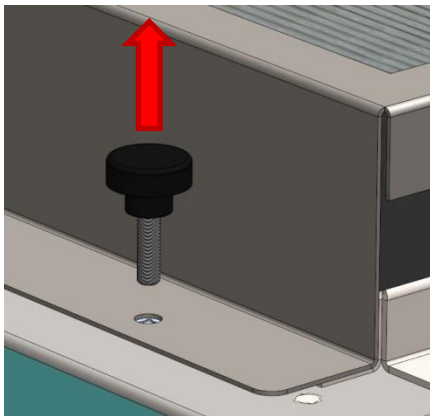

Troubleshooting



In the unlikely event of a problem with your DP400 please contact your local representative.

OR

BOFA Headquarters

19-20 Balena Close
Creekmoor industrial Estate
Poole
Dorset
BH17 7DU
UK
Phone: +44 (0) 1202 699 444

Email: Technical@bofa.co.uk
Website: www.Bofa.co.uk

OR

BOFA Americas

303 S.Madison Street
Staunton
Illinois
62088
USA
Phone: +1 (618) 205 5007

Email: info@bofaamericas.com
Website: www.bofaamericas.com

OR

BOFA International GmbH

Sudring 62
D-21465
Wentorf bei Hambury
Germany
Phone: +49 (0) 40 7393735-15

Replacement Parts



Consumable Spares

The DP400 system contains a pre filter and a HEPA filter. These should be replaced when the RED LED is flashing (see section 6 for replacing the filters)

To maintain performance it is important that the filters are replaced with identical BOFA filters.

Maintenance Protocol

Filter change information may also be recorded in the table below.

Unit Serial Number:			
Pre filter		HEPA filter	
Date	Engineer	Date	Engineer

Filter disposal

The Pre and Combined filters are manufactured from non-toxic materials. Filters are not re-usable, cleaning used filters is not recommended. The method of disposal of the used filters depends on the material deposited on them.

For your guidance

Deposit	EWC Listing*	Comment
Non Hazardous	15 02 03	Can be disposed of as non-hazardous waste.
Hazardous	15 02 02M	The type of hazard needs to be identified and the associated risks defined. The thresholds for these risks can then be compared with the amount of material in the filters to see if they fall into the hazardous category, if so, the filters will need to be disposed of in line with the local/national regulations.

*European Waste Catalogue

System Specifications



Unit: DP400

Capacity: 400m³/h (235cfm)

Weight: 9.1Kg (20lbs)

Motor: Centrifugal Fan

Output: 1100w

Electrical supply: 115-230V

Hertz: 50/60Hz

Full Load Current: 12.5A

Noise Level: Below 60dB (A)
(at typical operating speed)

Size:

	Metric (mm)	Imperial (inches)
Height	595	23.4
Depth	263	10.4
Width	283	11.1

Filters:

Filter Type	Efficiency
Pre filter	95% @ 0.9micron
HEPA	99.997% @ 0.3micron

Environmental operating range:

Temperature: +5°C to + 40°C

Humidity: Max 80% RH up to 31°C
Max 50% RH at 40°C

Contact Information

BOFA Headquarters

19-20 Balena Close
Creekmoor industrial Estate
Poole
Dorset
BH17 7DU
UK
Phone: +44 (0) 1202 699 444

BOFA Americas

303 S.Madison Street
Staunton
Illinois
62088
USA
Phone: +1 (618) 205 5007

BOFA International GmbH

Sudring 62
D-21465
Wentorf bei Hamburg
Germany
Phone: +49 (0) 40 7393735-15